

Product codes

A377901 White RAL 9010

Lamp codes

T641000 10° 2700K 700mA 410Lm
T642600 26° 2700K 350mA 840Lm
T643600 36° 2700K 350mA 840Lm

Drivers

DR48700 700mA
DR48350 350mA

Accessories

Y200100 Intumescent fire hood 150mm sq x 120mm
SG50 Sandblasted glass to provide an even wash without scallop.
HC50 Honeycomb louvre for extra low glare.
SL50 Lens for softening the scallop edge.
LL50 Spreader lens to elongate the beam width.
UV50 Ultra violet lens to limit UV.
Coloured glass lenses available on request.

Product notes

Energy efficient LED glass fronted waterproof directional downlight. Exclusive extra slim line bezel and deep 25mm dual black baffle system to reduce glare. Curly spring installation. Not suitable for lath and plaster ceilings. Designed to match the full range of John Cullen downlights.

Cut-out	60mm	
Beam Width	10°	26° and 36°
Colour Temperature	2700K	2700K
CRI	90	90
Lumens	410Lm	840Lm
Wattage	8.5w	12w
Forward Voltage (required minimum)	12vDC	36vDC
Current rating (maximum)	700mA	350mA
Efficacy	48.2Lm/w	70Lm/w
Wiring	Series	Series
IP rating	IP54	IP54
Lifetime at recommended current rating (70% LOR)	39000Hrs	39000Hrs
Dimmable	0-10v	0-10v

LED Technical information

The new John Cullen LED is a viable alternative to tungsten halogen. John Cullen continually research the latest available solution as technology develops.

Installation notes

- Connection** - Find a suitable accessible place for driver. Feed cable to required location.
- Installation** - Cut an accurate 60mm round hole, push fit the ceiling ring into place. Connect supply into the feed cable ensuring that the correct polarity has been observed (black cable -ve, red cable +ve). Please note if wired incorrectly the LED will be damaged. Once wired, place into ceiling ring and direct to desired position.
- Qualified electrician** - All electrical works to be carried out by a qualified electrician.
- Insulation** - Fitting requires a minimum recess depth and surrounding materials must be removed by 100mm from the outside edge of the fitting. Insulation must not be laid over the top of the fitting or fire hood.
- Fire box** - Please refer to fire boxing and fire hood installation sheet. Where fire prevention measures are required, we strongly recommend the preferred method that a firebox is constructed using fire protection board or plasterboard. A minimum area should be allowed between joists of at least 600mm long x 300mm wide x 120mm high, so that the transformer can be pushed 300mm away from the fitting. The cut-out should also be offset to one end to facilitate this.
- Fire hood** - Please refer to fire boxing and fire hood installation sheet. Only to be used where fire boxing is not possible. Only compatible and tested with Y200100 fire hood. Requires a minimum recess depth of 150mm. When using a fire hood clear away insulation materials and debris from around the fire hood by 100mm from the edge. Insulation materials to be removed clear above the fire hood. Transformers must be pushed away from the direction of tilt outside of the fire hood by a minimum of 100mm.
- Cable thickness** - Is the responsibility of the installer. Cable thickness must be calculated to avoid voltage drop. Calculations and cable tables can be found within the latest edition of the IEE wiring regulations.
- Positioning** - Positioning is subject to interior and installation requirements. Placement guides are available for a limited number of products. Guides can also be discussed with the design department.
- Decorating** - Light fittings should be dropped from the ceiling and bagged to prevent paint splash before decorating/painting takes place. Ideally fittings should not be lamped before site work is completed to maintain full lamp life.
- 0-10v Dimming** - Products can be dimmed on a 0-10v dimming signal when connected to the appropriate control device. When wiring 0-10v cable back to switch control, observe exact polarity for correct installation.
- Drivers** - Driver to be specified subject to installation requirements. Electrician to find discreet, accessible location for remote drivers. Calculating cable lengths and diameter to avoid voltage drop is the responsibility of the installer. For maximum distances please refer to specific driver specification sheet.
- Polarity** - The product must be connected with the correct polarity (black cable -ve, red cable +ve). Incorrect wiring will damage the product, JC will not take responsibility. Please see wiring schematics for further information.
- Ceiling thickness** - Not suitable for ceilings thinner than 5mm in thickness. Ceiling thicknesses greater than 24mm must be chamfered to allow air flow and ensure maximum tilt can be achieved.
- Driver capacity** - The maximum number of Aquabeam LED fittings that can be connected to a single driver is one unit.

PLEASE NOTE:-These notes are for guidance only. John Cullen accepts no responsibility for any installation using the above notes and the final decision on installation remains with the installer.



Designed in-house and manufactured in the UK. Exclusive to John Cullen.

Assembly guide

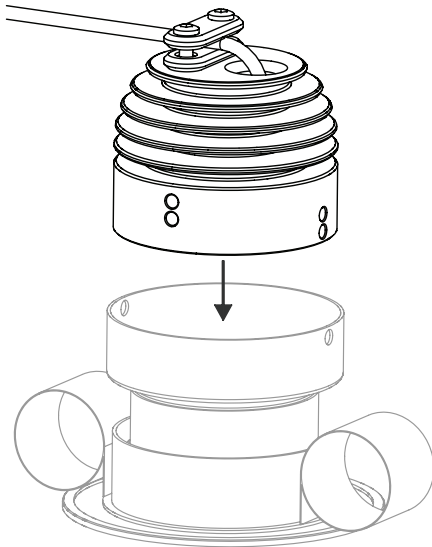

LOCATE ENGINE WITHING PRODUCT HOUSING AND PLACE.

*WHEN USING ACCESSORY LENSES AND FILTERS ENSURE THE LENSE IS PLACED FIRST.

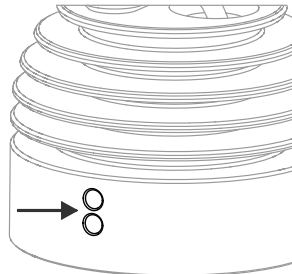

NOTE: THERE ARE TWO FIXING HOLES ON THE LED ENGINE.

THE LOWER IS USED FOR ASSEMBLY WITH AN ACCESSORY

THE UPPER IS USED FOR STANDARD ASSEMBLY.

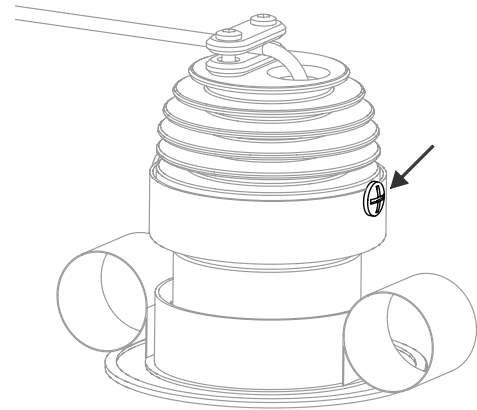

ONCE ASSEMBLED USE THE TWO PHILLIPS SCREWS PROVIDED ON THE LED ENGINE TO FIX INTO PLACE

INSTALL.

Wiring Diagram

26° and 36° Beam width

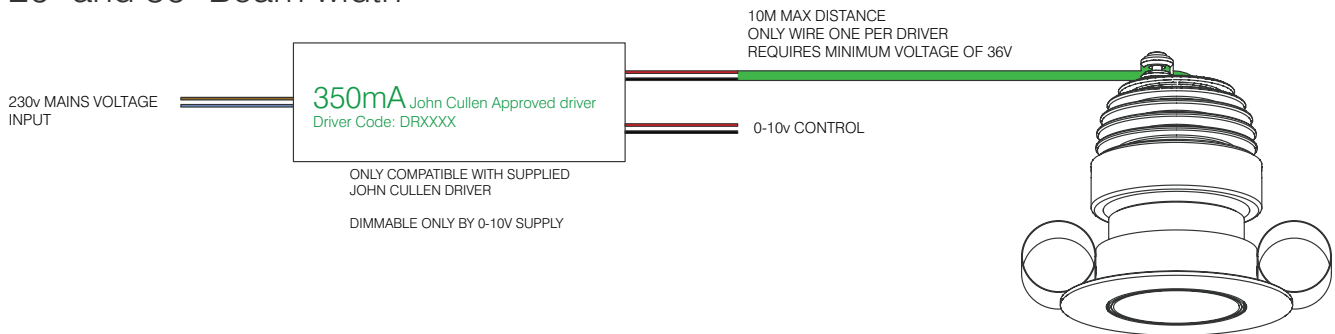

10° Beam width

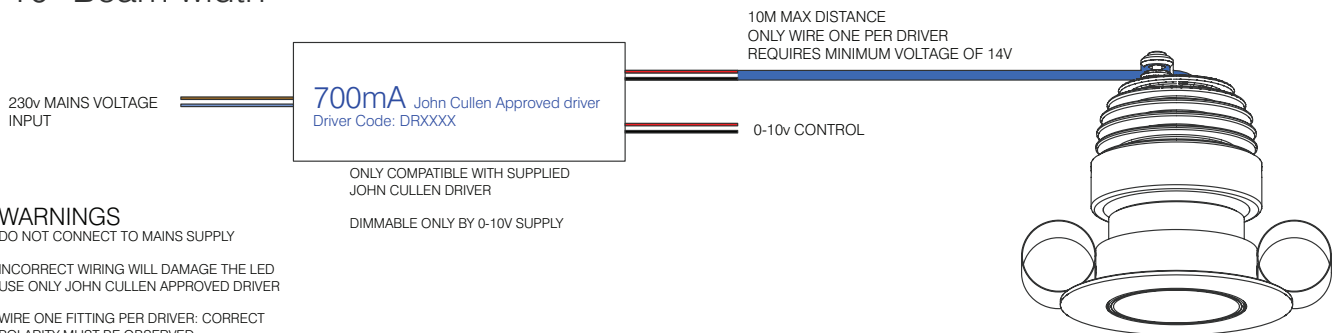

WARNINGS

DO NOT CONNECT TO MAINS SUPPLY

INCORRECT WIRING WILL DAMAGE THE LED
USE ONLY JOHN CULLEN APPROVED DRIVER

WIRE ONE FITTING PER DRIVER: CORRECT
POLARITY MUST BE OBSERVED

ENSURE POWER IS OFF WHEN WIRING
HOT WIRING WILL DESTROY LED